

# Specifications:

## 56G

### TURBOSTART™

### Starters

Specifically

Designed for

General Electric

LM1600 and LM2500

Gas Turbine Engines

## DIMENSIONAL DATA TDI 56G TURBOSTART™

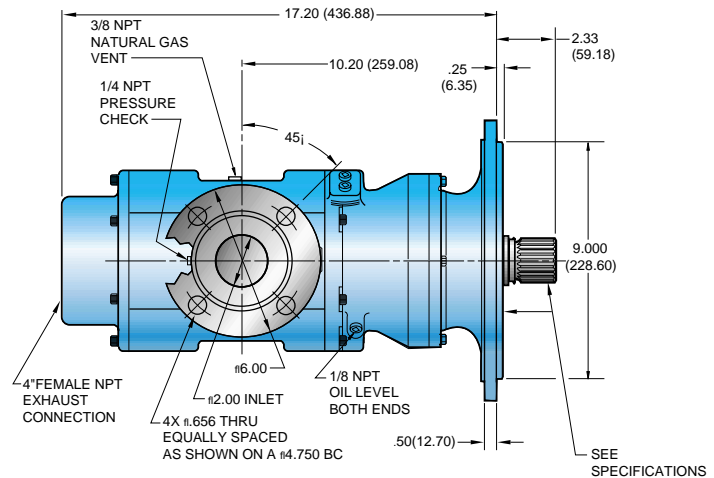

The Model 56G is lightest and most powerful in its class. It is also designed to replace aero-derived starters costing thousands more. Excellent availability, powerful performance, and a high tolerance for contaminated air supplies creates a solid value for application on GE gas turbine engines.

