

INSTALLATION AND OPERATING MANUAL

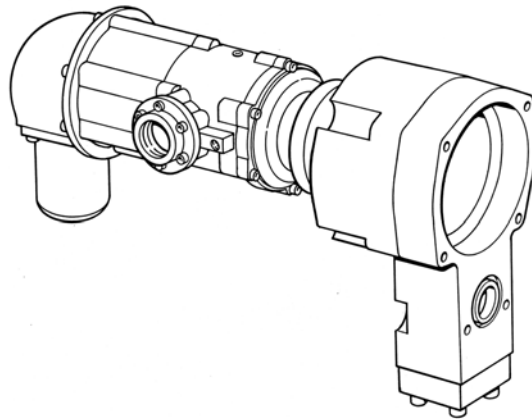

MODEL: T100-C (60057) **TURBOTWIN** Engine Air Starter

1.0 GENERAL INFORMATION

This manual provides instructions for the installation and operation of the TDI T100-C *TURBOTWIN* Air Starter. If there are questions not answered in this manual, please contact your TDI *TURBOTWIN* distributor or dealer for assistance.

The T100 *TURBOTWIN* starters are designed for operation with compressed air or natural gas; materials used are compatible with "sour" natural gas and marine environments. Small amounts of foreign matter or liquid in the air stream will not adversely affect *TURBOTWIN* starters. As with all other TDI starters, no lubrication is required in the air supply.

Please review the rest of this manual before installing the T100 *TURBOTWIN* series air starter.

WARNINGS, CAUTIONS AND NOTES

Certain types of information are highlighted in this manual for your attention:

WARNING - used where injury to personnel or damage to the equipment is likely.

CAUTION - used where there is the possibility of damage to the equipment.

NOTE - used to point out special interest information.

NOTE

Throughout this manual, the term "air" is used to designate the starter drive medium. Unless otherwise stated, air " means either compressed air or natural gas.

1.1 PRODUCT IDENTIFICATION

The starter nameplate which is attached to the turbine housing contains the following information: model number, serial number, part number, direction of rotation and the maximum rated operating pressure.

The maximum operating pressure is also stamped on the nameplate. This pressure is measured at the check port on the starter inlet with the starter in operation.

CAUTION

Exceeding the maximum pressure shown on the nameplate may result in damage to the starter or damage to the engine.

The housing proof pressure is 600 psig and is also shown on the nameplate. This means the turbine housing will not burst when subjected to a static pressure of 600 psig.

2.0 INSTALLING THE STARTER

A turbine air starter does not require lubrication in the supply air. Therefore, if a vane type starter motor is being replaced, TDI recommends that all lubrication devices and lines removed to minimize flow restrictions.

WARNING

If a fuel (pulse) lubricator has previously been installed in the system, disconnect and plug the line to eliminate spraying diesel fuel on the engine.

The starter should be installed with the inlet in a position between horizontal and straight down. Any condensation will be restricted to the air lines and not in the starter.

WARNING

Do not operate this starter unless it is properly connected to the engine.

The following steps can be used to properly install the T100-C on the engine:

- Remove the entire starting system from the skid. This includes the motors, starter gearbox pad, lubricators and inlet manifold. There should be six studs and the female portion of the "slot" drive remaining on the accessory gear case. The two 2" exhaust hoses can remain in place. Make note of the "clocking" positions of both the inlet and exhaust ports of the existing vane motors.
- Install a new O-ring around the bearing housing on the accessory gear case.
- Install the O-ring on the overflow hole (lower small hole) on the face of the T100-C (60057) housing.
- Position the male driver end of the "slot" drive on the starter motor in the vertical position.
- Position the female portion of the "slot" drive in the vertical position to match the male end.
- Install the T100-C housing assembly over the studs being careful not to damage the O-ring.
- Reinstall the washers and nuts.
- Remove the hex head screws that secure the TDI motor assembly to the flange casting.
- Without pulling the motor backwards and disengaging the "slot" drive positions, rotate the motor until the inlet is at the 9 o'clock position or positioned in the original position. Reinstall the TDI motor screws and tighten.

- You will have either a threaded or welded manifold for the air inlet that accommodates the lubricators and the two 2" inlet hoses at the base of the skid attached to the start gas inlet piping. If this is welded together use a pipe plug to block off one of the female holes as only one inlet hose will be used.
- If threaded, disassemble and create a manifold for only one hose from the remaining pieces. Remove one of the 2" NPT-hydraulic flange adapters from the inlet ports of one of the original air motors and install into the TDI motor using thread sealer.
- Reconnect the 2" hose from the air inlet at the base of the skid into the TDI starting motor.
- Remove the socket head screws holding the exhaust back cover and remove cover.
- Install TDI PN 2-28676 exhaust manifold (not include in 60057 assy) in the 6 o'clock position.
- Reinstall hex screws with minimal thread locking compound.
- Remove the exhaust 2" NPT-hydraulic flange adapters (2) from each of the removed (IR) vane motors and install into the installed TDI exhaust manifold using light thread sealer.
- Connect the existing 2" exhaust hoses to the hydraulic portion of the adapter.
- There is an oil feed tube that lubricates the gear case on the original (IR) gear case. Follow this tube to its source and remove. Cap the hole using a pipe plug.
- There are oil supply lines feeding the lubricators for the original vane motors. This supply line typically comes from the oil reservoir. Depending upon the application there could be two of these supply lines. Follow these lines back to their source and remove them.

NOTE

If the supply lines lead to the base of the engine oil reservoir have the pipe plugs ready to install quickly as oil will rush out from the reservoir.

3.0 SUPPLY LINE INSTALLATION

WARNING

Be sure to either bleed the pressurized air reservoir and/or safety the system such as closing all valves prior to installing starter supply line.

The *T100 -C* air starters come standard with a 2" NPT female pipe thread for the inlet connection port. The supply line consists of the line from the air source, a pressure regulator (when necessary), a manual or relay valve, and the connection to the starter inlet. Hard piping may be used, but a section of flexible tubing should be installed at the starter to prevent leaks due to engine vibration.

Care must be taken to ensure that all inlet supply line piping is no less than 1.5" and all components used are capable of passing the required air flow.

NOTE

Valves with a Cv of 40 or higher are recommended.

If the supply line must be longer than 20 feet, the inlet supply line piping should be increased to 2" in diameter to ensure proper performance by your **TURBOTWIN**.

Because turbine starters such as the **T100 TURBOTWIN series** are sensitive to flow restrictions, care must be taken to use uniform hose or tubing and fittings for connection of the supply line. Tees, elbows and line length must be kept to a minimum. TDI recommends that hose or flex couplings are installed to eliminate possible leakage caused by strain on the supply line.

Normally, an air strainer is not required. However, in dirty environments use of a #40 mesh Y-strainer is recommended. The **T100 TURBOTWIN series** is highly tolerant of dirt in the air line, however, starter life can be increased with the use of an air strainer.

A pressure regulator is required when the air supply pressure is great enough to exceed the starter operating pressure (at the inlet port) and/or the maximum torque.

The supply line should be dry-fitted for proper alignment /location prior to final assembly. All pipe threaded joints should be sealed with Loctite Pipe Thread Sealant (TDI P/N 9-94085) or equivalent for leak tight joints prior to final assembly. Be sure to tighten all joints to proper torque after final assembly.

CAUTION

In cold weather climates, care should be taken while designing your installation to prevent condensation from developing in the starter system. In systems with a regulator valve or relay valve, there is the possibility of freeze-ups.

A tee connection with a quick disconnect can be added to the inlet. This will allow an external air source to be used to accomplish a "blow start" if the system freezes. Once the engine has been started, the other system components may be thawed.

CAUTION

On new installations, it is strongly recommended to blow out the supply line with air to remove possible dirt and welding slag prior to final connection to the *TURBOTWIN* starter. Be sure to secure the free end of the supply line prior to blowing out the line.

4.0 INLET PRESSURE PORT

A 1/4" NPT port is located on the air inlet. This port may be used to check the supply pressure at the starter when the starter is operating. Remove the 1/4" NPT pipe plug and save for later use. Install a 1/4" minimum size tubing to the port. Route the tubing away from the starter to a safe location away from the engine. Install a pressure gauge on the tubing. This pressure monitoring line/gauge may be permanently installed. Use Loctite Pipe Thread Sealant or equivalent. Alternately, a pressure transducer may be installed at the pressure check port and electrical lines routed to a digital display at the operator's station.

This pressure port is invaluable in diagnosing air starter and/or installation problems.

5.0 EXHAUST PIPING

The turbine exhaust may be plumbed away from the starter area. All starters using natural gas must be piped according to industry codes and local regulations.

The performance of a turbine starter will be decreased because of back pressure when smaller than recommended exhaust piping is installed. If back pressure hampers starter performance, compensation can be made by increasing the supply pressure. Consult your TDI distributor for advice.

Exhaust piping should be routed downward to help prevent any accumulation of condensation in the starter motor.

If the overhung section of the starter is not otherwise supported, TDI recommends supporting the exhaust piping with a suitable bracket(s).

6.0 NATURAL GAS INSTALLATION

The installation of the starter using natural gas is similar to the air installation except all fittings, piping, valves and regulators must be compatible with natural gas.

Proper control of natural gas is a major consideration when used in the starter system. All starters using natural gas must pipe the exhaust according to industry codes and local regulations.

There is a natural gas vent port in the turbine housing that is plugged for compressed air use. This vent is used to remove any natural gas that could leak past the primary turbine shaft seal. Remove this 3/8"NPT plug and install a line to carry gas away from the starter area.

WARNING

Do not connect the turbine housing vent line to the turbine exhaust line. Exhaust gas can pressurize the housing.

7.0 PIPING SYSTEM

Only type approved metallic hose assemblies are approved in permanently pressurized compressed air lines of starters. Non-metallic hose assemblies are allowed only in case the piping system will be emptied after the starting procedure.

Pipe unions must be type approved by GL. Downstream of the pressure regulator a pressure relief valve is to be provided.

8.0 STARTER OPERATION

Prior to operation, check that all connections are tight and free from leaks. Check the 1/4" NPT pipe plug or a pressure gauge/transducer that may be connected to the pressure port on the starter inlet.

WARNING

Do not operate the TDI *TURBOTWIN* starter with air pressure greater than the pressure rating on the nameplate. This pressure is measured at the starter inlet while the starter is running.

The maximum operating pressure limit is the inlet pressure measured at the starter's inlet pressure check port. In order to check the starter, a 1/4"NPT pipe tap connection is provided in the inlet housing to attach a pressure gauge/transducer). The maximum pressure assumes an open exhaust (standard turbine exhaust guard). The standard exhaust guard causes no back pressure.

The static non-flowing supply pressure will always be higher than the operating (dynamic) pressure. The maximum pressure limit (proof pressure) that the TDI *TURBOTWIN* starter housings may be subjected to is 600 PSIG (42 BAR). System pressure that exceeds the maximum operating limit must use a pressure reducing device to ensure that the operating pressure limit to the TDI *TURBOTWIN* starter is maintained.

System static pressure that exceeds the 600 PSIG (42 BAR) limit must, in addition to pressure reducer devices incorporate a pressure relief valve set below 600 PSIG (42 BAR) in the supply air line.

All appropriate local pressure codes and pressure limitations on other system components must be adhered to and supersede the guidelines given in this manual.

Consult your TDI distributor if you have exhaust plumbing that creates back pressure and reduces starter performance. You may be able to increase the supply pressure to restore the lost power.

Follow the engine manufacturer's instructions for starting the engine.

9.0 PREVENTIVE MAINTENANCE

The TDI **TURBOTWIN** starters provide distinct advantages of size and efficiency as compared to electric motor, vane-type or other turbine-type starters. It is important to properly install the starter to receive full benefit of these advantages. Repair technicians or service organizations without turbine starter experience should not attempt to repair this starter until they receive factory approved training from TDI, or its representatives.

Proper operation and repair of your TDI TURBOTWIN starter will assure continued reliable and superior performance for many years.

9.1 Every Six (6) Months

Perform the following procedures at six (6) months intervals if the normal cranking cycle is 0 - 10 seconds.

9.1.1 Check the amount and condition of grease in the planetary gearbox. If gearbox requires re-greasing, only use TDI grease. Approximately one (1) pint of grease is needed to repack the gearbox.

9.1.2 Check the turbine bearing and carrier output bearings for freedom of rotation without excessive play between races. If bearings are damaged, replace them with genuine TDI parts. Refer to TDI Service Manual for part numbers.

9.2 Every Three (3) Months

Follow the six (6) month procedures if there are severe starter loading or extended duration crank cycles. Also perform these procedures every three (3) months when starter is used for motoring the engine for maintenance or valve adjustments.

 Motoring Crank Cycle: 10 -60 seconds

 Extended Crank Cycle: 60 seconds or longer

